

Operating Instructions

Meade® #884 Deluxe Field Tripod

For use with all ETX® telescopes

Introduction

The Meade #884 Tripod allows an ETX telescope to be mounted in either the altazimuth or the equatorial mode. The assembly includes a latitude adjustment control and a tilt-plate incorporated into the design.

Parts List

- Tripod (1) with attached tilt-plate (2) and latitude adjustment control (3) with latch (4).
- Two attachment knobs (5) for attaching an ETX telescope to the tilt-plate.
- Spreader tray (6). Separate spring, two washers, and tension knob (7) to attach tray to tripod.
- Three leg extension lock knobs (8).

How to assemble the tripod



Step 1: Spread the tripod (1) legs apart to a fully open position.

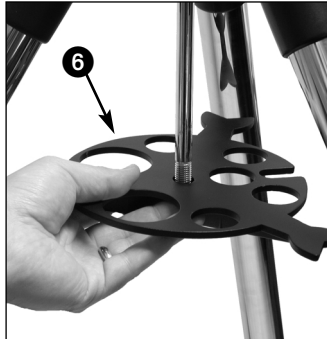

Step 2: Slide the spreader tray (6) onto the central threaded rod.



Step 3: Slide a washer, followed by the spring, another washer, and the tension knob (7) onto the threaded rod. Tighten the tension knob to a firm feel.

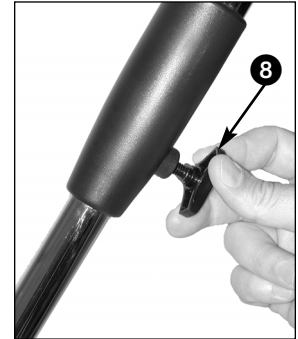

Step 4: Adjust the height of the tripod by loosening the leg lock knobs (8) and adjusting the height of the inner leg extensions. Then retighten the lock knobs.

Note: It is not necessary to tighten the spring (Step 3) to a fully compressed position. Tighten until the spreader tray holds the legs tightly without slipping.

Mounting your Telescope

As the Earth rotates on its axis, astronomical objects appear to move across the sky in an arc. This apparent motion is not obvious to the unaided eye, but when viewed through a telescope such as an ETX, this motion is rapid indeed. If the motor drive has not been engaged, celestial objects viewed in the telescope eyepiece drift entirely out of the field of view in 15 to 60 seconds, depending on the magnification employed.

However, by mounting your telescope and turning on the motor drive, you can counteract the drift of objects in the eyepiece. The two basic types of mounting are: altazimuth (alt/az) and equatorial. **It is unnecessary for ETX owners who use an Autostar Controller to equatorially mount the telescope. The Autostar Controller allows the telescope to be mounted in the altazimuth (alt/az) mode for all observing purposes.**

If you are using the ETX-70AT: Skip the "Equatorial Mount" section, below, and follow the procedure described in the section entitled "Altazimuth (Alt/Az) Mount."

If you are using the ETX-90/105/125 equipped with the optional Autostar hand controller: Skip the "Equatorial Mount" section, below, and follow the procedure described in the "Altazimuth Alt/Az Mount" section.

If you are using the ETX-90/105/125EC with Electronic Controller (EC): Follow the procedures in the "Equatorial Mount" section and skip the section entitled "Altazimuth (Alt/Az) Mount."

If you are using the ETX-90RA: Follow the procedures in the "Equatorial Mount" section and skip the section entitled "Altazimuth (Alt/Az) Mount."

Equatorial Mount

If you are using the Electronic Controller, use equatorial mounting. Mounting the telescope in this configuration lines up the telescope's polar axis with the North Celestial Pole (or the South Celestial Pole if observing in the southern hemisphere).

When using an equatorially mounted telescope, tracking (following) celestial objects is possible by turning on your ETX telescope's motor drive. The motor counteracts the Earth's rotation and keeps objects in the field of view of the eyepiece for hands-off tracking.

Equatorial Mounting Procedure

1. Loosen the latitude control latch (4, Fig. 1) and lift up the tilt-plate (2, Fig. 1) so that you can easily access the underside of the plate. Relock the latitude control latch, so the assembly doesn't slip while you are attaching the telescope. (See Fig. 1.)
2. Turn the tripod, so that the face of the tilt-plate points North (Figs. 7 and 8). If you attach the telescope to the tripod indoors, be sure to orient the face of the tilt-plate to point North after moving the telescope outdoors. Equivalently, point the tripod leg (9, Fig. 7) North. This is the leg *opposite* from the latitude control bar (3, Fig. 7).
3. **ETX-90RA model:** Line up the two mounting holes of your telescope over the attachment knobs (5, Fig. 3). Thread the attachment knobs into the base of the telescope. Tighten to a firm-feel only.

Important Note about the ETX-90RA model: The On/Off switch is located on the base of the drive base. This switch must be turned on before the telescope is mounted to the tilt-plate.

ETX-90EC, ETX-105EC, and ETX-125EC models with Electronic Controller (EC): Line up the mounting hole on the base of the telescope labeled "High Latitude Leg" with the attachment knob that is closest to the latitude control bar (see Fig. 2). Line up the other mounting hole with the remaining attachment knob. Thread both attachment knobs into the base of the telescope. Tighten to a firm-feel only. (See Fig. 3.)

4. Determine the latitude of your observing location from a road map, atlas, or the **LATITUDE CHART FOR MAJOR CITIES OF THE WORLD**, provided in your ETX manual. Loosen the latitude control latch (4, Fig. 4) and adjust the latitude control bar (3, Fig. 4) so that your observing site's latitude is just visible above the flat surface of the tripod head. Retighten the latch. (See Fig. 4.)
5. If you have not already done so, orient the tripod leg (9, Fig. 7) so that it is pointing due North (if the location of Polaris, the North Star, is known, point the telescope directly at Polaris. Observers located in the Earth's Southern Hemisphere must point the telescope due South). (See Figs. 7 and 8.)
6. The telescope is now equatorially mounted; the tripod must not be moved, or else the alignment will be lost. Instead, use one of the following methods to move the telescope's optical tube to a desired celestial object.
 - (a) Loosen the Horizontal (R.A.) and/or Vertical (Dec.) locks (see your telescope Operating Instructions) to permit the optical tube to be freely moved manually. Tighten the locks once you center on the object.
 - (b) With the Horizontal and Vertical locks in their "locked" positions, use the manual slow-motion controls (**ETX-90RA models**) or the Arrow keys of the Electronic Controller (**ETX-90EC, ETX-105EC, and ETX-125EC models**) to move the optical tube.

Note: For most astronomical observing requirements, approximate settings of the telescope's latitude and North-pointing tripod leg (steps 4 and 5, above) are acceptable. Do not allow undue attention to precise equatorial mounting of the telescope to interfere with your enjoyment of the instrument.

Using an Equatorially Mounted Telescope

Once your telescope is equatorially mounted, the telescope motor drive will keep a celestial object in the telescope eyepiece's field of view. To activate the tracking feature:

1. Center a celestial object in the eyepiece. See the appropriate section in your telescope's operating instructions for more information about locating celestial objects.
2. Activate your telescope's motor drive. The telescope now tracks the centered object.

ETX-90RA models: The On/Off switch is located on the base of the drive base. This switch **must be** turned on before the telescope is mounted to the tilt-plate. The telescope will automatically track astronomical objects: see the telescope's operating instructions for details in this regard. Use the telescope's manual slow motion controls to make minor adjustments to keep an object centered.

ETX-90EC, ETX-105EC, and ETX-125EC models with Electronic Controllers: The On/Off switch is located on the telescope's Computer Control panel. The telescope will automatically track astronomical objects; see the telescope's operating instructions for details in this regard. Use the Electronic Controller's Arrow keys to make minor adjustments to keep the object centered.

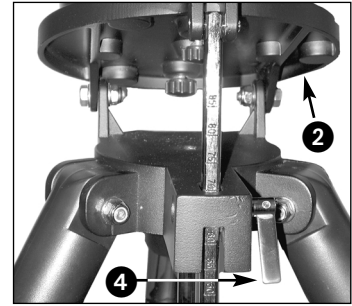

Fig. 1: Loosen control latch (4).

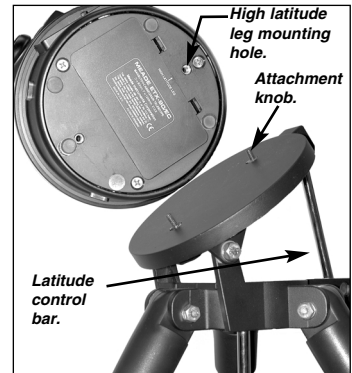

Fig. 2: High latitude leg mounting hole and corresponding attachment knob.

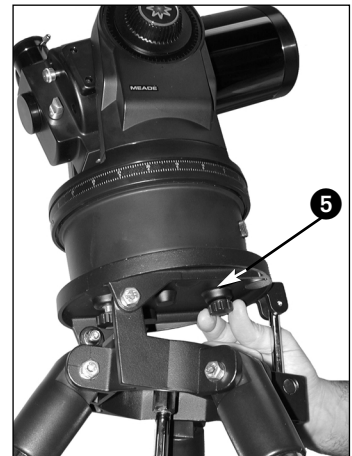

Fig. 3: Attach telescope to tripod.

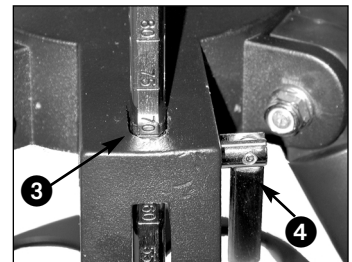

Fig. 4: Set latitude.

Note: If your telescope does not begin tracking when you activate the motor drive (you should hearing a "whirring" sound), check the configuration of the "mode screws" on the back of the Electronic Controller. See "Modes of Operation" in your telescope's operating instructions for more information.

Caution: Do not move the tripod or adjust the latitude setting while observing, or the mounting alignment will be lost.

Note: The telescope's motor drive disengages when the Horizontal and the Vertical lock levers are unlocked and re-engages when the levers are relocked.

3. At the end of an observing session, remember to turn off the motor drive.

Altazimuth (Alt/Az) Mount

Ideal for both terrestrial applications and also for astronomical observation with Autostar. Altazimuth (alt/az) mounting (from "altitude" meaning vertical and "azimuth" meaning horizontal) permits movement of the telescope tube in both the vertical (altitude) and the horizontal (azimuth) directions.

To mount your telescope in the alt/az mode:

1. Loosen the latitude control latch (4, Fig. 1) and lift up the tilt-plate (2, Fig. 1) so that you can easily access the underside of the plate. Relock the latitude control latch, so the assembly doesn't slip while you are attaching the telescope. (See Fig. 1.)
2. **ETX-70AT model:** Line up the two mounting holes of your telescope over the attachment knobs (5, Fig. 3). Thread the attachment knobs into the base of the telescope. Tighten to a firm feel only.

ETX-90EC, ETX-105EC, and ETX-125 models with Autostar: Line up the mounting hole on the base of the telescope marked "High Latitude Leg" with the attachment knob that is closest to the latitude control bar (see Fig. 2). Line up the other mounting hole with the attachment knob at the bottom of the tilt-plate. Thread both attachment knobs into the base of the telescope. Tighten to a firm feel only. (See Fig. 3.)

3. Unlock the latitude control latch (4, Fig. 4) and lower the tilt-plate until it is level (push the tilt-plate down until it stops; this is the level position). Lock the latitude control latch. (See Fig. 6.)

Using an Alt/Az Mounted telescope

The telescope is now altazimuth mounted on the #884 Tripod. Motions of the telescope may be effected in either horizontal or vertical directions. ETX telescopes equipped with an Autostar hand controller (standard equipment with the ETX-70AT; optionally available for the ETX-90EC, ETX-105EC, and ETX-125EC) may be used in the altazimuth mode, and the Autostar hand controller directs the telescope to track astronomical objects in both vertical and horizontal directions, simultaneously. Note that in the case of altazimuth mounting, the orientation of the tripod is irrelevant: the tripod may be placed on the ground with tripod legs pointing in arbitrary directions. For information on the use of your ETX telescope equipped with an Autostar hand controller, consult your telescope's operating instructions.



Fig. 6: Altazimuth Alignment. Note that the tilt-plate is level.

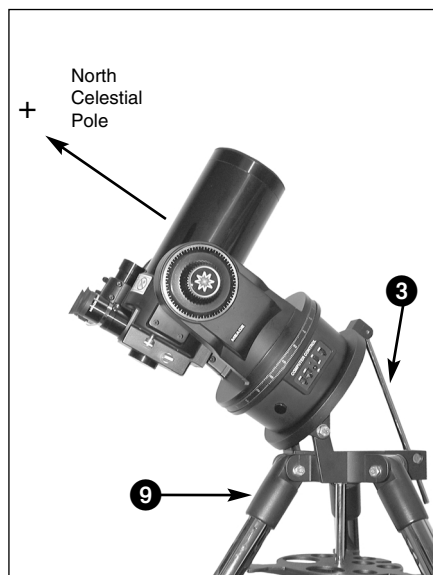

Fig. 7: Example of Polar Alignment. Note that the face of the tilt-plate points North.

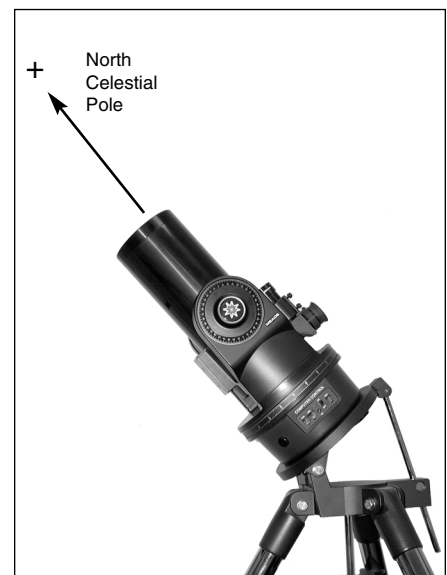

Fig. 8: Example of Polar Alignment. Note that the face of the tilt-plate points North.

Locating the Celestial Pole

Using the North Star (Polaris) to find North is useful in equatorial mounting. Polaris is the tail star of the Little Dipper; however, the Little Dipper is made up of dim stars and is not always easily located. A simple way of locating Polaris is to draw an imaginary line from the so-called "pointer" stars of the Big Dipper to Polaris (see diagram below). In the Southern hemisphere, locate South by using the faint star Sigma Octantis (the South Star).

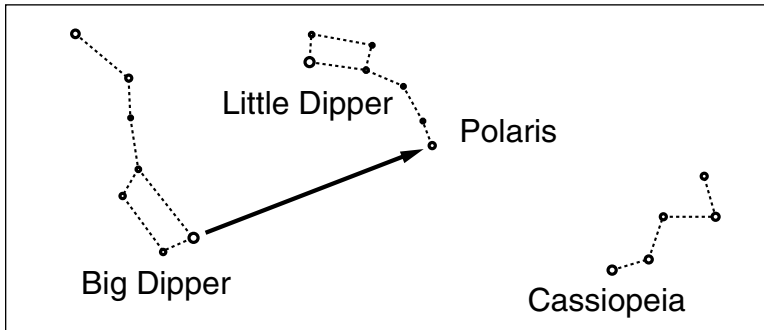

Fig. 9: Locating Polaris.

If you have a question concerning use of the Meade **#884 Deluxe Field Tripod**, call the Meade Instruments Customer Service Department at (949) 451-1450, or fax to (949) 451-1460. Customer Service hours are 8:30 AM to 4:30 PM, Pacific Time, Monday through Friday.



ADVANCED PRODUCTS DIVISION
Meade Instruments Corporation

World's Leading Manufacturer of Astronomical Telescopes for the Serious Amateur
6001 Oak Canyon, Irvine, California 92618 ■ (949) 451-1450
FAX: (949) 451-1460 ■ www.meade.com

© 2001

Part no. 14-0269-00 Ver. 6-02